

# 多轴自动锁螺丝机

# Multi-Axis Automatic Screw Locking Machine

# 使用说明书

# User Manual

公司名称：深圳市驰速自动化设备有限公司

Company: Shenzhen Chisu Automation Equipment Co., Ltd.

地 址：广东省深圳市宝安区沙井镇新沙路鑫鑫田工业园八栋、九栋

Address: Building 8 & 9, Xinxintian Industrial Park, Xinsha Road, Shajing Town,  
Bao'an District, Shenzhen, Guangdong Province, China

电 话：

Telephone:

## 目 录

### Table of Contents

一、设备简介 .....	4
<b>I. Machine Overview .....</b>	<b>4</b>
二、设备结构介绍 .....	5
<b>II. Machine Components .....</b>	<b>5</b>
三、设备特点 .....	8
<b>III. Machine Features .....</b>	<b>8</b>
四、设备电气规格 .....	9
<b>IV. Electrical Specifications .....</b>	<b>9</b>
五、操作安全申明 .....	9
<b>V. Safety Precautions .....</b>	<b>9</b>
六、设备工作前检查 .....	10
<b>VI. Pre-Operation Inspection .....</b>	<b>10</b>
七、工作流程图 .....	11
<b>VII. Workflow Diagram .....</b>	<b>11</b>
八、手动调试操作(换产品时只需调试一次，后续有变动再进行微调) .....	11
<b>VIII. Manual Configuration (This procedure is only required during initial product changeover. Any subsequent adjustments may simply involve fine-tuning.) .....</b>	<b>11</b>
九、自动运行操作 .....	14
<b>IX. Automatic Operation .....</b>	<b>14</b>
十、画面以及按键功能说明 .....	15
<b>X. Screens and Button Functions .....</b>	<b>15</b>
1、安全提示画面 .....	15
1. Safety Prompt Screen .....	15
2、联系信息画面 .....	16
2. Contact Information Screen .....	16
3、主页 .....	17
3. Home Screen .....	17
4、系统设置-基本参数画面 .....	19
4. System Settings - Basic Parameters Screen .....	19
5、系统设置-下料臂参数画面 .....	21
5. System Settings - Arm Parameters Screen .....	21
6、系统设置-伺服批参数画面（下图是普通伺服批参数说明） .....	23
6. System Settings - Servo Screwdriver Parameters Screen (for Standard Servo Screwdriver Only) .....	23
7、系统设置-伺服批开关设置画面 .....	24
7. System Settings - Servo Screwdriver Switch Settings Screen .....	24
8、系统设置-滑牙检测功能置画面 .....	25
8. System Settings - Stripping Detection Function Settings Screen .....	25
9、系统设置-送钉机检测功能置画面 .....	26
9. System Settings - Feeder Detection Function Setting Screen .....	26
10、手动调试画面（手动模式下操作） .....	27

10. Manual Configuration Screen (in Manual Mode Only).....	27
11、I/O 画面-输入.....	28
11. I/O Screen - Output.....	28
12、I/O 画面-输出.....	29
12. I/O Screen - Input.....	29
13、批头型号画面.....	30
13. Bit Model Screen.....	30
14、设备报警信息提示窗口.....	30
14. Alarm Message Prompt Window.....	30
15、用户权限登录窗口.....	31
15. User Permission Login Window.....	31
<b>十一、报警信息原因分析.....</b>	<b>32</b>
<b>XI. Alarm Analysis.....</b>	<b>32</b>
<b>十二、故障以及处理.....</b>	<b>35</b>
<b>XII. Troubleshooting.....</b>	<b>35</b>
1、系统不能启动：检查启动条件输入线路和外部硬件；启动条件如下：自动模式、启动按钮指示灯处于熄灭状态、机械臂正好位于安全位置上时机械臂升降气缸必须在上位并输入点有信号、系统无报警发生、系统复位完成、伺服未全部禁用、转盘停止检测无信号、锁付升降气缸上磁环有信号、启动按钮按下。（系统无法启动时会有对应条件报警信息弹出）.....	35
1. System Fails to Start: Check if the input wiring and external hardware meet start conditions. Prerequisites Check: Operation mode set to Auto; Start button indicator off; robotic arm in safety position (lifting cylinder raised with signal); no active alarm present; system reset successfully; not all servos disabled, turntable stop detection signal absent, locking cylinder upper magnetic ring signal detected; Start button activated. (Alarm messages will automatically appear when abnormalities are detected).....	35
3、转盘到位后不锁付产品：检查产品到位检测传感器和输入线路。.....	36
3. No Locking Operation After Turntable In Position: Check the product presence detection sensor and its input circuits.....	36
4、锁付升降气缸不能上下动作：首先查看对应输出点是否输出，检查控制电磁阀以及输出线路，检查气源。.....	36
4. Locking Cylinder Fails to Move Up/Down: Verify if the controller output is active. Inspect solenoid valve operation and output wiring. Verify that the air supply is functioning properly.....	36
5、系统启动后下降过程中伺服批不启动：首先查看伺服批输出点是否输出，检查伺服控制输出线路。.....	36
5. Servo Screwdriver Fails to Start during Descent: Verify if the servo screwdriver output is active. Check the servo control output circuits.....	37
7、下料臂不工作：查看系统设置-基本参数中下料功能是否启用。.....	37
7. Arm Inactive: Navigate to System Settings > Basic Parameters and ensure the unloading function is enabled.....	37
8、下料臂抓取产品后不能上升：检查夹紧产品后是否与治具之间卡死，然后查看机械臂升降气缸上升输出点是否输出，检查控制电磁阀以及输出线路，检查气源。.....	37
8. Arm Fails to Retract After Pick-Up Operation: Check if the fixture is jammed after a product is picked up. Verify if the elevation output of the robotic arm lifting cylinder is active. Inspection the control solenoid valve and output wiring. Verify that the air supply is functioning properly.....	37

9、下料臂升降气缸不能升降动作：首先查看对应输出点是否输出，检查控制电磁阀以及输出线路，检查气源。 .....	37
9. Arm Lifting Cylinder Fails to Move Up/Down: Verify if the corresponding output is active. Inspect solenoid valve operation and output wiring. Verify that the air supply is functioning properly. ....	37
10、下料臂手指不能动作：首先查看对应输出点是否输出，检查控制电磁阀以及输出线路，检查气源。 .....	37
10. Gripper Inactive: Verify if the corresponding output is active. Inspect solenoid valve operation and output wiring. Verify that the air supply is functioning properly. ....	38
11、下料臂到放料位后不放产品：检查手指气缸动作是否正常。 .....	38
11. Arm Fails to Release Product in Unloading Position: Check the gripper cylinder for normal operation. ...	38
十三、设备保养 .....	38
<b>XIII. Machine Maintenance .....</b>	<b>38</b>

## 一、设备简介

### I. Machine Overview

多轴自动锁螺丝机是由螺丝供料系统、自动拧紧机构、多工位转盘机构、自动下料构四部分完美组合而成。螺丝供料系统通过压缩空气将螺丝吹送到批嘴（吹气式），气缸执行机构带动伺服批完成自动拧紧产品螺丝，拧紧完成后采用闭环步进电机机械臂自动取出产品。设备采用双手启动作业安全性高，机器可以 24 小时不停机工作，设备操作简单、锁付速度快、效率高、为企业节省人工成本等优势。

The multi-axis automatic screw locking machine comprises four key components: the screw supply system, automatic tightening mechanism, multi-station turntable mechanism, and automatic unloading mechanism. The screw supply system uses compressed air to pneumatically feed screws to the bit nozzle. The cylinder actuator drives the servo screwdriver to automatically tighten the screw. After this, the robotic arm, powered by a closed-loop stepper motor, retrieves the finished product. The machine enables two-handed start operation for enhanced safety and features 24/7 operational capability, ensuring simple operation, fast locking speed, high efficiency, and significant labor cost reduction.

**注：**以下介绍中根据多轴机械臂机型讲解，固定式请忽略机械臂和转盘的相关操作。

**NOTE:** The following instructions pertain specifically to the multi-axis robotic arm model. Operations related to the robotic arm and turntable are not applicable to fixed variants.

## 二、设备结构介绍

### II. Machine Components

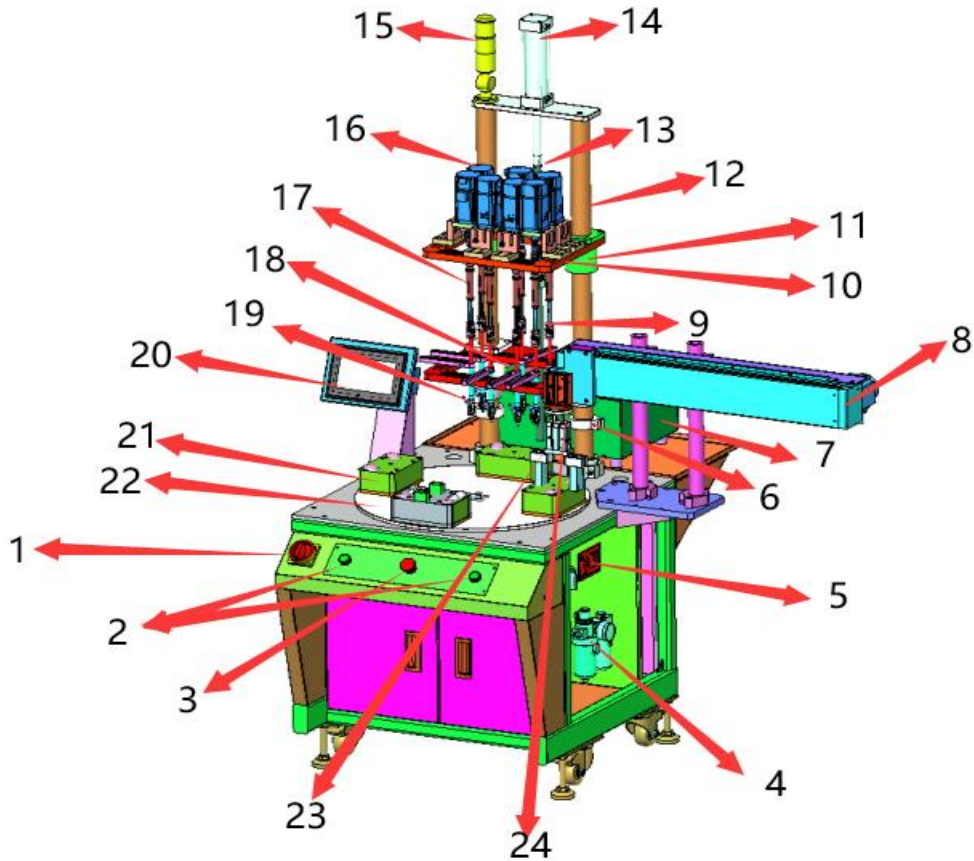

(1)电源开关

(1) Main Power Switch

(2)双手启动按钮（自动模式下启动按钮灯未点亮时则可启动系统）

(2) Two-Hand Start Buttons: In automatic mode, the machine can only be started when the Start button indicator is off.

(3)急停旋钮（用于紧急情况下停止系统并复位气缸动作到初始状态）

(3) Emergency Stop Button: Press this button to immediately stops the machine and resets all cylinders to their initial state in case of emergency.

(4)气源调压油水分离两联件

(4) Air Preparation Unit (Pressure Regulator + Oil-Water Separator)

(5)设备铭牌

(5) Machine Nameplate

(6)定位夹（定位批嘴与产品的间距）

(6) Positioning Clamp: To adjust the distance between the bit nozzle and the product.

(7)螺钉供料机

(7) Screw Feeder

(8)下料臂

(8) Arm

(9)下滑板压力弹簧与调节螺母

(9) Lower Slider Compression Spring and Adjustment Nut

(10)上滑板抬升高度调整螺母（调节批头与批嘴的距离）

(10) Upper Slider Lifting Height Adjustment Nut: To adjust the distance between the screwdriver bit and the bit nozzle.

(11)直线轴承组件

(11) Linear Bearing Assembly

(12)高硬度立柱

(12) High-Hardness Column

(13)上滑板压力弹簧与调节螺母

(13) Upper Slider Compression Spring and Adjustment Nut

(14)锁付机构升降气缸

(14) Locking Mechanism Lifting Cylinder

(15)三色指示灯（黄：空闲；绿：运行；红：故障）

(15) Tricolor Indicator: Yellow (Idle), Green (Running), Red (Error)

(16)伺服批

(16) Servo Screwdriver

(17)传动轴组件与批头

(17) Transmission Shaft Assembly and Screwdriver Bit

(18)下滑板抬升高度调节螺母（调节批嘴与产品之间的距离）

(18) Lower Slider Lifting Height Adjustment Nut: To adjust the distance between the bit nozzle and the bit nozzle.

(19)批嘴

(19) Bit nozzle

(20)HMI 人机界面

(20) HMI (Human-Machine Interface)

(21)治具

(21) Fixture

(22)转盘

(22) Turntable

(23)下料臂手指气缸

(23) Gripper Cylinder

(24)下料臂升降气缸

(24) Arm Lifting Cylinder

### 三、设备特点

#### III. Machine Features

1、驰速多轴自动锁螺丝机均选用知名品牌气缸、直线导轨、PLC、HMI 人机界面、电磁阀、伺服批(电动起子、气动起子)等组成锁付机构与控制系统，设备具有耐用性强、锁付可靠性高等特点。

1. The Chisu multi-axis automatic screw locking machine integrates high-quality components—including leading-brand cylinders, linear guides, PLCs, HMIs, solenoid valves, and servo screwdrivers (electric or pneumatic)—into a robust locking mechanism and control system, ensuring exceptional durability and reliable locking performance.

2、螺丝供料器采用最新式的分料结构，噪声小，送螺丝可靠性高，卡料自复位实现送螺丝免维护。

2. The screw feeder incorporates an innovative distribution mechanism that ensures quiet, highly reliable operation. Its automatic jam clearance function enables virtually maintenance-free feeding.

3、可根据不同螺丝制定不同的螺钉供料方式。

3. The feeding method can be customized to suit specific screw types.

4、可根据不同产品定制非标化设备达到客户锁付要求。

4. Non-standard solutions can be provided according to different product and locking requirements.

5、设备控制方面采用 PLC+HMI 人机界面，操作直观并且后期改造和检修等极为便利。

5. The machine is controlled via an integrated PLC and HMI, designed for intuitive operation and ease of future modification and maintenance.

6、全中文界面(可根据客户要求定制他国语言), 自主研发自动锁螺丝控制系统, 可实时监控系统状态等数据。

6. The machine features a fully Chinese interface (other languages available upon request) and a proprietary control system for real-time monitoring of all machine status and data.

#### 四、设备电气规格

#### IV. Electrical Specifications

1、输入电源: AC220V 50HZ (可根据不同国家定制)

1. Power Supply: AC220V, 50 Hz (Configurable for regional standards)

2、输入气源: 0.4-0.6Mpa

2. Air Supply: 0.4-0.6 Mpa

3、额定功率: 1.6KW(400W 四轴)

3. Rated Power: 1.6 kW (400 W per axis X 4 axes)

**注: 额定功率是指伺服满力矩堵转未及时断开时的最大功率, 而在日常使用时实际功率不会有这么大。**

**NOTE: Rated power refers to the maximum power when the servo is stalled at full torque without timely disconnection. Typical operational power consumption is significantly lower.**

#### 五、操作安全申明

#### V. Safety Precautions

- 1、 凡有安全标识提示说明的请严格按照说明操作设备。
  1. Strictly adhere to operational instructions where safety signs are displayed.
- 2、 操作人员禁止使用脚踏开关，必须使用双手启动按钮来启动设备。
  2. The machine must be started exclusively using the two-hand Start buttons. The use of foot switches is prohibited.
- 3、 机器运行时，严禁将身体任何部位放入设备台面以内的范围。
  3. Keep all body parts outside the working table during operation.
- 4、 在手动调试设备时请将双手离开后再进行执行机构的操作。
  4. Ensure hands are clear before operating any actuator during manual configuration.

## 六、设备工作前检查

### VI. Pre-Operation Inspection

- 1、 气源是否正常。
  1. Verify that the air supply unit is functioning properly.
- 2、 送钉机是否正常。
  2. Verify that the screw feeder is functioning properly.
- 3、 送料管内是否有螺钉。
  3. Verify that the feeding tube is loaded with screws.
- 4、 批嘴里是否有螺钉。
  4. Verify that a screw is present in the screwdriver bit.
- 5、 各个 I/O 点是否正常。
  5. Verify that all I/O points are functioning properly.

6、执行机构是否运行正常。

6. Verify that all actuators are functioning properly.

## 七、工作流程图

### VII. Workflow Diagram

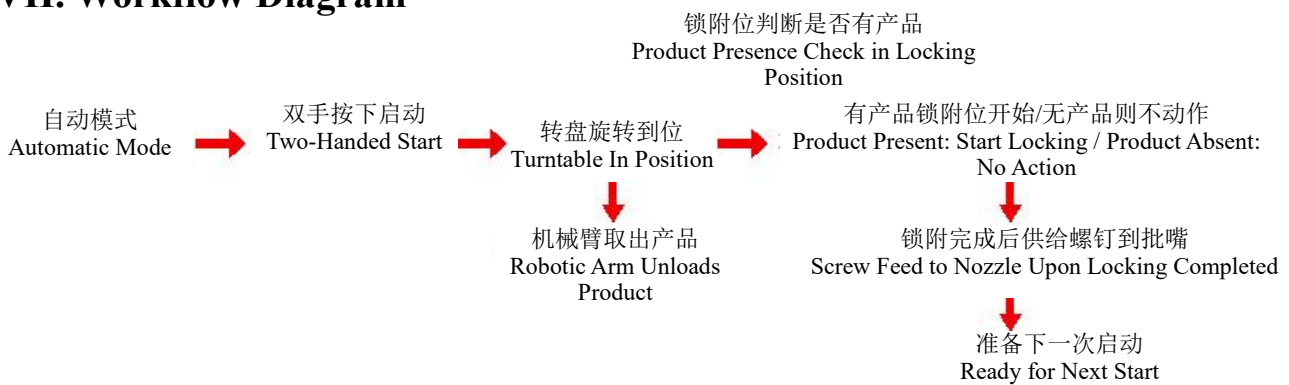

八、手动调试操作(换产品时只需调试一次，后续有变动再进行微调)

### VIII. Manual Configuration (This procedure is only required during initial product changeover. Any subsequent adjustments may simply involve fine-tuning.)

1、将已经锁付好的产品按照正确方向放入转盘上的治具内。

1. Place a reference product (a correctly assembled part) into the fixture on the turntable, ensuring it is oriented properly.

2、从主画面单击【手动调试】按键进入调试画面，单击【转盘】按键直至放入产品工位旋转至锁付位(提示：锁付升降气缸和机械臂升降气缸必须在上位才能操作，未在上位时会有异常报警提醒)。

2. Navigate to the Home screen and select [Manual Configuration] to access the configuration screen. Then, click the [Turntable] button until the loaded fixture is rotated to the locking position (NOTE: This operation can only be performed when both

the locking cylinder and the robotic arm lifting cylinder are retracted. Otherwise, an alarm will be activated).

3、将传动轴从活接卡扣中取出。

3. Disengage the drive shaft from the quick-connect coupling.

4、点动操作【锁付升降气缸升】与【锁付升降气缸降】按键将批嘴调整到与产品距离 5-10mm 处。

4. Press the [Locking Cylinder Up] and [Locking Cylinder Down] buttons in jogging mode to position the bit nozzle 5-10 mm from the product.

5、微松开传动轴固定夹与滑板紧固螺钉，将批嘴移至到需要锁付孔位上并把批头插入螺钉槽中且来回旋转批头对位，确认对位 OK 后紧固此固定夹的螺钉；后续螺钉位置调整一样同上操作步骤。

5. Loosen the drive shaft clamp and the slider fastening screws slightly. Move the bit nozzle to the desired locking position, insert the screwdriver bit into the screw slot and rotate the screwdriver bit back and forth for alignment. Once it is aligned correctly, tighten the screw in this clamp. Follow the same procedure to adjust the position of other screws.

6、所有调整完毕后将批嘴调整到与产品表面没有接触的高度并把两根立柱下方定位夹锁死固定。

6. After all adjustments are completed, move the bit nozzles to a height where they do not contact the product surface, and then secure the positioning clamps at the bottom of the two columns.

7、让升降气缸回到最上位后从批嘴进钉口看里面批头有没有挡住进料口，如果挡住则将上滑板定位螺母向上旋直至调整到合适的位置。

7. Retract the lifting cylinder to its topmost position. Inspect the screw inlet of the bit nozzle to ensure the screwdriver bit is not obstructing the path. If obstruction occurs, rotate the positioning nut on the upper slider counterclockwise to raise the assembly until the inlet is clear.

8、所有工位治具都要放入产品核对螺钉位置是否一致，若不一致可松开治具紧固螺钉微调（这样位置不一致的几率很小，因为我司生产的零部件都是自主数控加工）。

8. Load products into all fixtures at the work stations and verify that all screw positions are aligned correctly. If not, loosen the fastening screws on the fixtures for minor adjustment (NOTE: Misalignment risk is minimal due to our in-house CNC machining process).

9、将产品放入下料位治具中，将机械臂移动到抓取位置打开手指下降调好手指张开中心距，合上手指后上下操作机械臂升降气缸取放产品自然即可。

9. Place a product into the fixture at the unload station. Move the robotic arm to the pick-up position. Open the gripper, and adjust the opening center distance. Close the gripper and operate the robotic arm lifting cylinder to complete a pick-and-place cycle.

10、调整好后将该位置当前坐标填入到取料坐标中。（提示：第9和第10步必须在系统复位完成的情况下进行）

10. After the adjustment is completed, set the current position as the pick-up coordinates. (NOTE: Steps 9 and 10 must be performed after a successful system reset).

11、设置好下料坐标和安全坐标，下料坐标即为卸料位置，安全坐标则指到达此位置时转盘可旋转。

11. Set the unloading coordinates and safety coordinates, respectively. Unloading coordinates define the finished product discharge position. Safety coordinates define the position that enables turntable rotation.

12、以上完成后检查所有螺钉是否紧固。

12. Upon completion of the above steps, verify that all screws on the machine are securely tightened.

注：以上调试均在手动模式下进行

NOTE: All the above configuration operations must be performed in manual mode.

## 九、自动运行操作

### IX. Automatic Operation

1、接通气源 4-6MP 电源 AC220V50HZ

1. Connect the air supply (4-6 MPa) and power supply (AC220V, 50 Hz).

2、打开主机电源开关。

2. Turn on the Main Power Switch.

3、等待 HIM 启动完成后应认真阅读安全提示后进入系统。

3. After the HMI boots up, carefully read the safety prompts and then enter the system.

4、启动前应检查最大锁付时间、送钉时间、送钉启动时间、伺服启动时间、异常检测时间（默认 5 秒）是否设置正确并检查批嘴里有无螺丝，若无则应单击【送钉】按键送入螺丝到批嘴里。

4. Before startup, verify the following parameters are set correctly: maximum locking time, screw feeding time, and servo start time, and fault detection time (default: 5 s). Confirm the presence of a screw in the screwdriver bit. If absent, press the [Feed] button to load one.

5、单击【手动】切换按钮切换为自动模式，触摸屏左上第二排状态显示会跟随变化。

5. Click the [Manual] toggle button to switch automatic mode. The status display in the top left corner of the touchscreen updates accordingly.

6、以上工作完成后，将产品放入第一工位治具内，双手按下主机前面板的【启动】按钮系统将运行，触摸屏左上第二排显示‘工作中’锁付流程开始工作（流程见第七节），系统启动后按钮指示灯点亮，等熄灭后方可再次按下启动按钮启动系统。

6. Then place a product into the fixture at the first work station, and press the [Start] buttons on the front panel with two hands. The system begins operation, and the touchscreen displays "Running" in the second row at the upper left corner. The locking cycle now commences (refer to Section VII for the detailed workflow). The start button indicator illuminates during operation. The system can only be restarted after the indicator turns off.

## 十、画面以及按键功能说明

### **X. Screens and Button Functions**

#### 1、安全提示画面

##### 1. Safety Prompt Screen

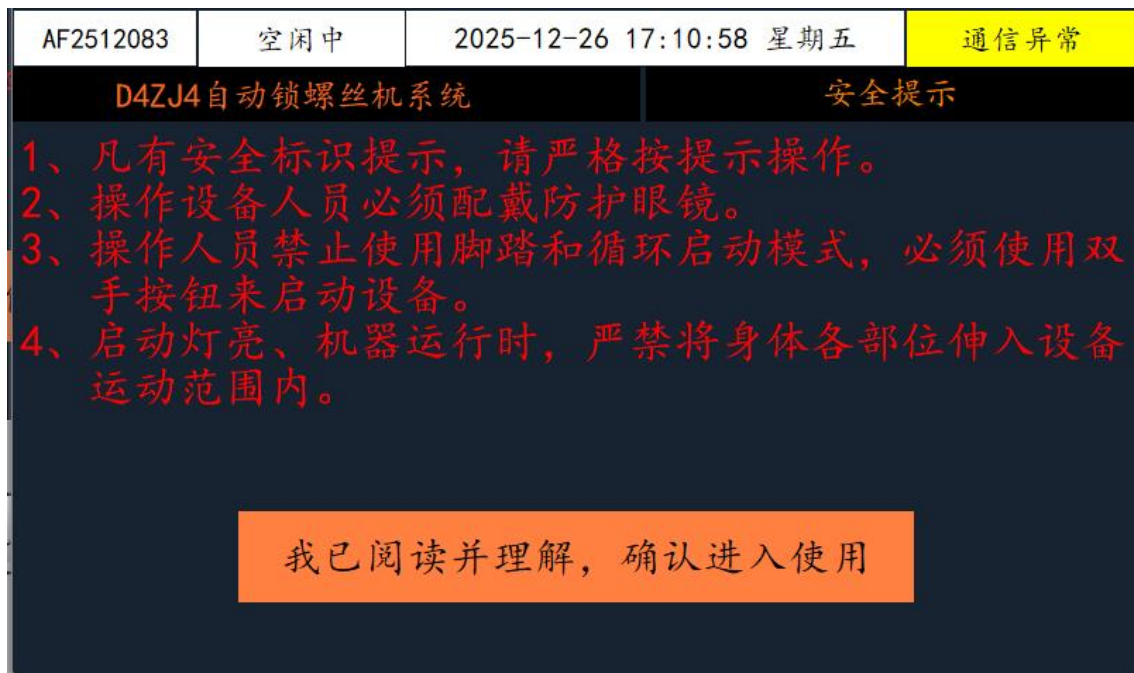

提示操作人员在使用设备中需要注意的安全事项。

This screen displays critical safety precautions that must be observed by the operator when using the machine.

## 2、联系信息画面

### 2. Contact Information Screen



AF2512083:设备编号（购买配件以及同我司售后部处理问题时使用）。

AF2512083: Machine ID (Please reference this number when ordering parts or requesting technical support).

【退出】：返回主页面

[Exit]: Returns to the Home screen.

### 3、主页

#### 3. Home Screen



(1)设备编号。

(1) AF2509167: Machine ID.

(2)显示系统当前状态。（空闲、工作中、复位中）

(2) Idle: Display the current status of the machine. (idle/running/resetting)

(3)显示当前北京时间。

(3) 2025-10-28 Tue 14:47: Display the current Beijing Time.

(4)显示系统模式。（手动模式、自动模式）

(4) Manual Mode: Display the current mode of the machine. (manual mode/automatic mode)

(5)显示转盘工位示意图。

(5) Show the diagram of the turntable station

(6)显示与 PLC 连接是否正常。

(6) Communication Abnormal: Indicate if the connection to the PLC is normal.

(7)设备机型。

(7) D4ZJ4 Automatic Screw Locking Machine: Display the model of the machine.

(8)界面名称。

(8) Title: Display the title of the current screen.

(9)总产量计数。（使用产量清零按键清零或满 99999999 自动清零）

(9) Total output count. (Use the Clear Output button or auto-clears at 99999999)

(10)系统自手动模式切换功能按键。

(10) Manual/Auto Button: Switch between manual and automatic modes.

(11)产量清零按键。（系统空闲时长按 2S）

(11) Clear Output Button: Hold for 2 s in idle state.

(12)机械臂复位按键。（系统空闲下单击）

(12) Reset Button: Reset the arm. Click only in idle state.

(13)送钉按键。（系统空闲下单击）

13) Feed Button: Click only in idle state.

(14)进入系统设置按键。

(14) System Settings: Enter the system settings screen.

(15) 进入批头型号查看按键。

(15) Bit Model: Enter the screwdriver bit model screen.

(16) 进入手动调试按键。

(16) Manual Configuration: Enter the manual configuration screen.

(17) 进入 PLC 输入输出监控界面。

(17) I/O Check: Enter the PLC input/output monitoring screen.

(18) 进入联系方式查看界面。

(18) Contact Information: Enter the contact information screen.

#### 4、系统设置-基本参数画面

#### 4. System Settings - Basic Parameters Screen



(1) 设置螺丝拧紧需要的最大时间。

(1) Max Locking Time: Set the maximum time for locking a screw.

(2)设置螺丝送入批嘴需要的时间。

(2) Screw Feeding Time: Set the time required to feed a screw to the bit nozzle.

(3)设置送钉启动时间。锁付结束延时此时间触发送钉

(3) Feed Start Delay: Set the time delay. after the locking cycle completes before initiating the screw feeding process.

(4)设置伺服启动时间。锁付气缸开始下降延时此时间启动伺服

(4) Auto Start Delay: Set the time delay. between the locking cylinder descent and servo activation.

(5)设置感应信号异常判断时间。（默认 5S）

(5) Error Detection Time: Set the time for determining a sensor signal error. (default: 5 s)

(6)设置屏保时间。

(6) Screen Saver Time: Set the activation time for the screen saver.

(7)设置转盘停止时间。（默认 0.19S,出厂已设置，厂商设置）

(7) Turntable Stop Time: Set the duration for which the turntable stops. (default: 0.19 s - preset at factory by the manufacturer)

(8)设备自动下料功能设置。（系统空闲下可设置）

(8) Auto Unloading Function: Enable/Disable the auto unloading function.

(configurable only when the system is idle)

(9)设置下料臂是否下降后放开产品。（系统空闲下可设置）

(9) Unloading & Descending: Enable/Disable the function to release the product after the unloading arm descends. (configurable only when the system is idle)

(10)其它系统设置界面切换菜单选项。

(10) Menu: Switch to other system settings screens.

## 5、系统设置-下料臂参数画面

### 5. System Settings - Arm Parameters Screen



(1)下料臂向左移动按键。（手动模式切空闲状态操作）

(1) Left: Press this button to move the arm to the left. (The operation is only allowed in manual mode when system is idle)

(2)下料臂当前位置显示。

(2) Display the current position of the arm.

(3)下料臂向右移动按键。（手动模式切空闲状态操作）

(3) Right: Press this button to move the arm to the right. (The operation is only allowed in manual mode when system is idle)

(4)取料坐标设置。（空闲状态）

(4) Pick-Up Coordinates: Set the pick-up coordinates. (available only in idle state)

(5)下料坐标设置。（空闲状态）

(5) Unloading Coordinates: Set the unloading coordinates. (available only in idle state)

(6)安全坐标设置，防止转盘旋转时与机械臂碰撞的安全位置。（空闲状态并需使用操作员权限，密码 123456）

(6) Safety Coordinates: Set the safety coordinates, which define the position to prevent collision between the turntable and the robotic arm during rotation. (Available only in idle state; Operator permission level required; Password: 123456)

(7)下料臂运行速度（频率）设置。

(7) Operating Speed: Set the arm operating speed (frequency).

(8)下料臂最大行程设置。（出厂已设置，厂商设置）

(8) Max Travel: Set the maximum travel of the arm. (preset at factory by the manufacturer)

(9)单击按键移至取料坐标。（手动模式切空闲状态操作）

(9) To Pick-Up Position: Press this button to move the arm to the pick-up coordinates. (The operation is only allowed in manual mode when system is idle)

(10)单击按键移至放料坐标。（手动模式切空闲状态操作）

(10) To Unloading Position: Press this button to move the arm to the unloading coordinates. (The operation is only allowed in manual mode when system is idle)

(11)单击按键移至安全坐标。（手动模式切空闲状态操作）

(11) To Safety Position: Press this button to move the arm to the safety coordinates.

(The operation is only allowed in manual mode when system is idle)

(12)单击下料臂升降气缸上升。（手动模式切空闲状态操作）

12) Up: Press this button to move arm up. (The operation is only allowed in manual mode when system is idle)

(13)单击下料臂升降气缸下降。（手动模式切空闲状态操作）

(13) Down: Press this button to move arm down. (The operation is only allowed in manual mode when system is idle)

(14)单击下料臂手指打开。（手动模式切空闲状态操作）

(14) Gripper Open: Press this button to open the gripper. (The operation is only allowed in manual mode when system is idle)

(15)单击下料臂手指夹紧。（手动模式切空闲状态操作）

(15) Gripper Close: Press this button to close the gripper. (The operation is only allowed in manual mode when system is idle)

(16)示教速度。（空闲状态）

(16) Slow: Display the teach speed. (available only in idle state)

6、系统设置-伺服批参数画面（下图是普通伺服批参数说明）

6. System Settings - Servo Screwdriver Parameters Screen (for Standard Servo Screwdriver Only)



(1)拧紧螺丝的扭力设置。（智能伺服批分三段扭力设置应遵循从小至大的顺序）

(1) Locking Torque: Set the torque for tightening screws. (For smart servo screwdrivers, set three-stage torque parameters in ascending sequence)

(2)拧紧螺丝的转速设置。（智能伺服批分三段速度设置应遵循从大至小的顺序）

(2) Locking Speed: Set the rpm for tightening screws. (For smart servo screwdrivers, set three-stage speed parameters in ascending sequence)

## 7、系统设置-伺服批开关设置画面

## 7. System Settings - Servo Screwdriver Switch Settings Screen



(1)伺服批编号。（与锁付孔位编号对应）

(1) This field displays the servo screwdriver numbers. (corresponding to the locking position numbers)

(2)当前编号的伺服批启用或禁用设置。（空闲状态允许设置）

(2) Enabled: Enable/Disable the servo screwdriver with the current number. (configurable only in idle state)

8、系统设置-滑牙检测功能置画面

8. System Settings - Stripping Detection Function Settings Screen



(1)锁付孔位编号。（与伺服批编号对应）

(1) This field displays the locking position numbers. (corresponding to the servo screwdriver numbers)

(2)当前锁附孔位启用或禁用滑牙检测报警功能。

(2) Disabled: Enable/Disable the servo screwdriver with the current number.

## 9、系统设置-送钉机检测功能置画面

## 9. System Settings - Feeder Detection Function Setting Screen



启用或禁用送钉机故障报警功能。

Enabled: Enable/Disable the feeder fault alarm function.

### 10、手动调试画面（手动模式下操作）

### 10. Manual Configuration Screen (in Manual Mode Only)



(1)锁付升降气缸上升点动按键。

- (1) Locking Mechanism Lifting Cylinder UP: Press this button to move the locking mechanism lifting cylinder up in jogging mode.
- (2)锁付升降气缸下降点动按键。
- (2) Locking Mechanism Lifting Cylinder Down: Press this button to move the locking mechanism lifting cylinder down in jogging mode.
- (3)转盘启动按键。
- (3) Turntable: Press this button to activate the turntable.
- (4)伺服批启动按键。
- (4) Servo: Press this button to activate the servo screwdriver.

## 11、I/O 画面-输入

### 11. I/O Screen - Output

AF2512083	空闲中	2025-12-26 16:54:31 星期五	通信异常
<b>D4ZJ4自动锁螺丝机系统</b>		<b>输入监控</b>	
● X0_下料臂电机原点信号	● X14_2号扭力检测信号		
● X1_启动按钮	● X15_3号扭力检测信号		
● X2_急停按钮	● X16_4号扭力检测信号		
● X3_锁付升降气缸上磁环	● X33_下料臂驱动故障信号		
● X4_下料臂升降气缸上磁环			
● X5_下料臂升降气缸下磁环			
● X6_下料臂手指气缸开磁环			
● X7_下料臂手指气缸合磁环			
● X10_转盘到位检测信号			
● X11_锁付位产品到位信号			
● X12_送钉机准备OK信号			
● X13_1号扭力检测信号			
主页	系统设置	手动调试	输入监控
			输出监控
			批头型号
			联系信息

(1)当前输入点位的状态显示。（红色无信号，绿色有信号）

1) This symbol displays the status of the current input. (Red: No signal, Green: Signal present)

(2) PLC 输入点位编号以及对应输入的硬件名称。

(2) This field displays PLC output number and the corresponding hardware name.

## 12、I/O 画面-输出

### 12. I/O Screen - Input



(1)当前输出点位的状态显示。（红色无信号，绿色有信号）

(1) This symbol displays the status of the current output position. (Red: No signal, Green: Signal present)

(2)PLC 输出点位编号以及对应控制的硬件名称。

(2) This field displays PLC output number and the corresponding controlled hardware name.

### 13、批头型号画面

#### 13. Bit Model Screen

AF2512083		空闲中		2025-12-26 16:40:35 星期五		通信异常	
D4ZJ4自动锁螺丝机系统					批头型号		
1	1	2	CSPM6	11	0	21	0
	2		0	12	0	22	0
	3		0	13	0	23	0
	4		0	14	0	24	0
	5		0	15	0	25	0
	6		0	16	0	26	0
	7		0	17	0	27	0
	8		0	18	0	28	0
	9		0	19	0	29	0
	10		0	20	0	30	0
主页		系统设置		手动调试		输入监控	
		输出监控		批头型号		联系信息	

(1)批头编号。（与伺服批编号对应）

1) This field display the screwdriver bit number. (corresponding to the servo screwdriver numbers)

(2)批头型号。（出厂已设置，可根据此型号购买批头）

(2) This field displays the screwdriver bit model. (Factory preset. Reference this model number when ordering replacements)

### 14、设备报警信息提示窗口

#### 14. Alarm Message Prompt Window



清除故障提示信息时必须处理好故障后才可清除，解除故障时需注意安全。

Always clear fault messages only after implementing corrective actions and verifying system safety.

## 15、用户权限登录窗口

## 15. User Permission Login Window



操作员用户密码：123456

Operator user password: 123456

## 十一、报警信息原因分析

### XI. Alarm Analysis

序号 Code	报警描述-静态文本 Alarm Description - Static Text
1	系统紧急停止中 (X2) System in Emergency Stop (X2)
2	下料臂超出最大行程! Arm Overtravel!
3	系统未复位! System Not Reset!
4	下料臂驱动异常 (X33) Arm Drive Fault (X33)
5	1 号滑牙报警 No. 1 Stripping Alarm
6	2 号滑牙报警 No. 2 Stripping Alarm
7	3 号滑牙报警 No. 3 Stripping Alarm
8	4 号滑牙报警 No. 4 Stripping Alarm
9	锁付升降气缸上磁环异常 (X3) Locking Mechanism Lifting Cylinder Upper Magnetic Ring Fault (X3)
10	下料臂升降气缸上磁环异常 (X4) Arm Lifting Cylinder Upper Magnetic Ring Fault (X4)
11	下料臂升降气缸下磁环异常 (X5) Arm Lifting Cylinder Lower Magnetic Ring Fault (X5)
12	下料臂手指气缸开磁环异常 (X6) Gripper Cylinder Open Magnetic Ring Fault (X6)
13	下料臂手指气缸合磁环异常 (X7) Gripper Cylinder Close Magnetic Ring Fault (X7)
14	转盘到位信号异常 (X10) Turntable In-Position Signal Fault (X10)
15	送钉机准备 OK 信号异常 (X12) Feeder Ready OK Signal Fault (X12)
16	下料臂未在安全位置! Arm Not in Safe Position!
17	伺服批已全禁，无法正常启动!

All Servo Screwdrivers Disabled - System Start Inhibited!
---

(1)急停旋钮按下，输入线路断线或者急停旋钮损坏。

(1) The emergency stop button is engaged; the input wiring is broken; or the emergency stop button is damaged.

(1)设置的相应坐标超出最大行程，重新设置即可。

(2) The set coordinates exceed the maximum travel; reset coordinates correctly.

(3)系统未进行复位，清除报警后复位系统。

(3) The system has not been reset; clear the alarm and reset the system.

(4)下料臂驱动发生故障，驱动红灯闪烁，或者 X43 与 OV 短路造成报警。

(4) Arm drive failure (red indicator); or X43-OV short circuit.

(5)-(8)锁付螺丝滑丝或者漏锁，若无滑丝和漏锁进入 I/O 画面观察扭力检测信号是否正常，或者输入线路断线。

(5)-(8) Stripped/missing screws; check if the torque signal is normal in the I/O screen or if the input wiring is broken.

(9)锁付升降气缸上端磁环损坏，输入线路断线，气缸未升到顶端，磁性开关位置不正确，气源压力不足，异常检测时间设置过短。

(9) The locking mechanics cylinder upper magnetic ring is damaged; the input wiring is broken; the cylinder is not retracted; the magnetic switch is in an incorrect position; the air supply pressure is insufficient; the fault detection time is set too short.

(10)下料臂升降气缸上端磁环损坏，输入线路断线，气缸未升到顶端，磁性开关位置不正确，气源压力不足，异常检测时间设置过短。

(10) The arm lifting cylinder upper magnetic ring is damaged; the input wiring is broken; the cylinder is not retracted; the magnetic switch is in an incorrect position; the air supply pressure is insufficient; the fault detection time is set too short.

(11) 下料臂升降气缸下端磁环损坏，输入线路断线，气缸未降到底，磁性开关位置不正确，气源压力不足，异常检测时间设置过短。

(11) The arm cylinder lower magnetic ring is damaged; the input wiring is broken; the cylinder is not fully extended; the magnetic switch is in an incorrect position; the air supply pressure is insufficient; the fault detection time is set too short.

(12) 下料臂手指开磁环损坏，输入线路断线，气缸未完全打开，磁性开关位置不正确，气源压力不足，异常检测时间设置过短。

(12) The gripper open magnetic ring is damaged; the input wiring is broken; the cylinder is not fully opened; the magnetic switch is in an incorrect position; the air supply pressure is insufficient; the fault detection time is set too short.

(13) 下料臂手指合磁环损坏，输入线路断线，气缸未完全夹紧，磁性开关位置不正确，气源压力不足，异常检测时间设置过短。

(13) The gripper cylinder close magnetic ring is damaged; the input wiring is broken; the cylinder is not fully closed; the magnetic switch is in an incorrect position; the air supply pressure is insufficient; the fault detection time is set too short.

(14) 转盘到位检测传感器损坏，控制中间继电器或者固态继电器损坏，转盘电机损坏，转盘电机线路以及转盘到位检测输入线路断线。

(14) The turntable in-position detection sensor is damaged; the control intermediate relay or solid-state relay is damaged; the turntable motor is damaged; the wiring in the turntable motor circuit and in-position detection input circuit is broken.

(15)送钉机故障，输入线路断线。

(15) The screw feeder is malfunctional; the input wiring is broken.

(16)下料臂安全坐标设置错误，下料臂未处于安全坐标范围。

(16) The arm safety coordinates are set incorrectly; the arm is not within the range of the safe coordinates.

(17)伺服批全部处于禁用状态，到系统设置-伺服批开关画面启用需要用到的伺服批即可。

(17) All servo screwdrivers are disabled. Enable the desired servo screwdrivers in the System Settings - Servo Screwdriver Switch screen.

## 十二、故障以及处理

### **XII. Troubleshooting**

1、系统不能启动：检查启动条件输入线路和外部硬件；启动条件如下：自动模式、启动按钮指示灯处于熄灭状态、机械臂正好位于安全位置上时机械臂升降气缸必须在上位并输入点有信号、系统无报警发生、系统复位完成、伺服未全部禁用、转盘停止检测无信号、锁付升降气缸上磁环有信号、启动按钮按下。（系统无法启动时会有对应条件报警信息弹出）

1. System Fails to Start: Check if the input wiring and external hardware meet start conditions. Prerequisites Check: Operation mode set to Auto; Start button indicator off; robotic arm in safety position (lifting cylinder raised with signal); no active alarm

present; system reset successfully; not all servos disabled, turntable stop detection signal absent, locking cylinder upper magnetic ring signal detected; Start button activated. (Alarm messages will automatically appear when abnormalities are detected)

2、系统启动后转盘不旋转：检查 PLC 输出点是否有 DC24V 电压输出，检查转盘电机控制继电器触点是否导通,若未导通则用万用表 AC250V 档位测量转盘驱动电机控制电源线路有没有 AC220V 电压若有则需将电机寄回我司检测维修。

2. Turntable Fails to Rotate after System Start: Verify if the PLC output provides DC24V voltage. Inspect the turntable motor control relay contacts for continuity. If no continuity is detected, use a multimeter on AC250V range to measure whether the turntable drive motor control circuit carries AC220V voltage. If voltage is present, return the motor to the manufacturer for inspection and repair.

3、转盘到位后不锁付产品：检查产品到位检测传感器和输入线路。

3. No Locking Operation After Turntable In Position: Check the product presence detection sensor and its input circuits.

4、锁付升降气缸不能上下动作：首先查看对应输出点是否输出，检查控制电磁阀以及输出线路，检查气源。

4. Locking Cylinder Fails to Move Up/Down: Verify if the controller output is active. Inspect solenoid valve operation and output wiring. Verify that the air supply is functioning properly.

5、系统启动后下降过程中伺服批不启动：首先查看伺服批输出点是否输出，检查伺服控制输出线路。

5. Servo Screwdriver Fails to Start during Descent: Verify if the servo screwdriver output is active. Check the servo control output circuits.
- 6、锁付完成不送螺钉：检查送钉机是否卡螺钉，送钉机的电源气源是否正常。
6. No Screw Feeding After Locking: Check for jammed screws in the feeder. Verify that the power and air supply to the feeder are functioning properly.
- 7、下料臂不工作：查看系统设置-基本参数中下料功能是否启用。
7. Arm Inactive: Navigate to System Settings > Basic Parameters and ensure the unloading function is enabled.
- 8、下料臂抓取产品后不能上升：检查夹紧产品后是否与治具之间卡死，然后查看机械臂升降气缸上升输出点是否输出，检查控制电磁阀以及输出线路，检查气源。
8. Arm Fails to Retract After Pick-Up Operation: Check if the fixture is jammed after a product is picked up. Verify if the elevation output of the robotic arm lifting cylinder is active. Inspection the control solenoid valve and output wiring. Verify that the air supply is functioning properly.
- 9、下料臂升降气缸不能升降动作：首先查看对应输出点是否输出，检查控制电磁阀以及输出线路，检查气源。
9. Arm Lifting Cylinder Fails to Move Up/Down: Verify if the corresponding output is active. Inspect solenoid valve operation and output wiring. Verify that the air supply is functioning properly.
- 10、下料臂手指不能动作：首先查看对应输出点是否输出，检查控制电磁阀以及输出线路，检查气源。

10. Gripper Inactive: Verify if the corresponding output is active. Inspect solenoid valve operation and output wiring. Verify that the air supply is functioning properly.

11、下料臂到放料位后不放产品：检查手指气缸动作是否正常。

11. Arm Fails to Release Product in Unloading Position: Check the gripper cylinder for normal operation.

提示：当系统出现异常时都会弹出对应报警信息，可根据信息中提示的 PLC 输入点处理故障。

NOTE: Alarm messages will automatically appear and indicate PLC inputs to guide troubleshooting when abnormalities are detected.

### 十三、设备保养

#### XIII. Machine Maintenance

1、工作结束后应关闭电源和气源，并打扫干净设备上的灰尘清扫掉落的螺钉等物体。

1. After work, turn off the power and air supply; then clean the machine and remove any dust or loose screws.

2、定期给各执行结构加防锈润滑油(T32#)，建议一月一次。

2. Apply anti-rust lubricant (T32#) to all actuators on a regular basis. Monthly application is recommended.

3、定期检查设备上的所有紧固螺丝有无松动。

3. Check all fastening screws on the machine for looseness on a regular basis.

4、在设备长期不使用的情况下应保养一次并用缠绕膜包好放在干燥的环境中。

4. If the machine is not used for an extended period, perform maintenance, then wrap the machine with protective film and store it in a dry environment.